

# VA-7200 Electric Valve Actuator

## Introduction

The VA-720x Series synchronous motor driven actuator provides floating or proportional control of valves, with up to 19mm stroke in heating, ventilation and air conditioning applications.

This compact, non-spring return actuator has a 1000N nominal force and responds to a variety of input signals.

The VA-7200 Series can be easily field mounted or ordered factory coupled to VG7000, VG8000, VG9000 and VGS8000 Series valves in accordance with the specified maximum close-off pressure ratings (see pertinent valve bulletins).



VA-7200

| Features and Benefits   |   |
|---|---|
| <input type="checkbox"/> <b>1000N Force Output compact unit</b> | Covers a wide range of applications with one actuator   |
| <input type="checkbox"/> <b>Magnetic clutch</b>                 | Provides constant output force for positive close-off of valves, and protects motor in stall conditions   |
| <input type="checkbox"/> <b>“Signal fail” safe position</b>     | Valve safety position after control signal failure, the safety position, up / down, is selectable in-situ |

## Ordering data

For VG7000 Series Valves

| Item Code    | Control, Power Supply   |
|--------------|---|
| VA-7200-1001 | Floating control, 24 VAC supply                                 |
| VA-7202-1001 | Proportional control (0...10 VDC / 0(4)...20 mA), 24 VAC supply |

For VG8000, VG9000 and VGS8000 Series Valves

| Item Code    | Control, Power Supply   |
|--------------|---|
| VA-7200-8201 | Floating control, 24 VAC supply                                 |
| VA-7202-8201 | Proportional control (0...10 VDC / 0(4)...20 mA), 24 VAC supply |

## Actuator / valve combinations

The VA-7200 can be combined with the following valve ranges:

- VG7000 Series Cast Bronze Valves
- VG8000 Series PN16 and PN25 Flanged Valves
- VG9000 Series PN6 and PN10 Flanged Valves
- VGS8000 Series Male Threaded Valves

For complete ordering information, please refer to the relevant product bulletin

## Operation

### Floating control models

| Connections | Actuator Stem | "Signal fail" safe position |
|-------------|---------------|-----------------------------|
| 1-2         | extends       | N / A                       |
| 1-3         | retracts      | N / A                       |

### Proportional control models (0...10 V or 0...20 mA)

| Jumper function | Input control signal | Actuator Stem | "Signal fail" safe position |
|-----------------|----------------------|---------------|-----------------------------|
| Direct action   | increases            | extends       | selectable                  |
|                 | decreases            | retracts      | selectable                  |
| Reverse action  | increases            | retracts      | selectable                  |
|                 | decreases            | extends       | selectable                  |

"Signal Fail" safe position (only for Voltage input)

A signal failure on proportional models will cause the actuator to automatically move the stem to a (via jumper) pre-selected position (100% extended or 100% retracted).

## Ordering procedure

The actuator can be ordered as a separate unit or a factory fitted valve-actuator combination. Should the latter be requested, please just add "+M" to the end of the actuator ordering code.

For example:

Item 1 **VG7203AT** (valve body)

Item 2 **VA-7202-1001** (actuator)

Alternatively, to order a factory fitted combination.

Item 1 **VG7203AT** (valve body)

Item 2 **VA-7202-1001+M** (actuator)

## Mounting instructions

When mounting the actuator on a valve, please follow the instructions below:

- It is recommended that the valves be mounted upright in an easily accessible location. When mounted horizontally, the yoke should be fitted such that the stanchions are aligned vertically, one above the other.

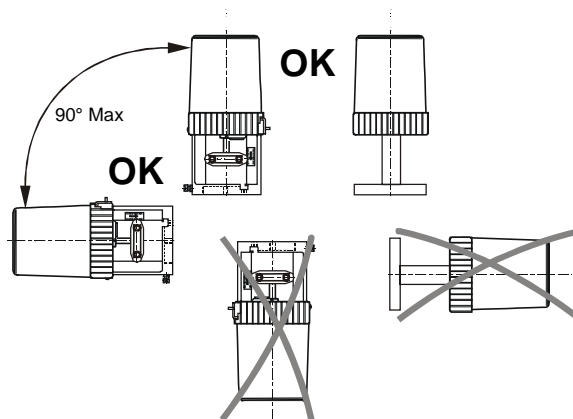

- The actuator must be protected against dripping water, which could enter the housing and damage the mechanism or motor.
- Do not cover with insulating material.
- Sufficient clearance must be allowed for actuator removal (refer to the dimension drawings).
- The valve must be installed so that the plug seats against the flow, as indicated by the arrows on the valve.

## Wiring instructions

- All wiring must be in accordance with local regulations and national electrical codes and should be carried out by authorised personnel only.
- Make sure that the line power supply is in accordance with the power supply specified on the device.
- See also the instructions in paragraph "Application".

### WARNING

#### Shock Hazard

Disconnect the power supply before wiring connections are made to prevent personal injury.

#### Equipment Damage Hazard

Make and check all wiring connections before applying power to the system. Short circuited or improperly connected wires may result in permanent damage to the unit.

## Wiring Diagrams:

### Floating model 24 VAC

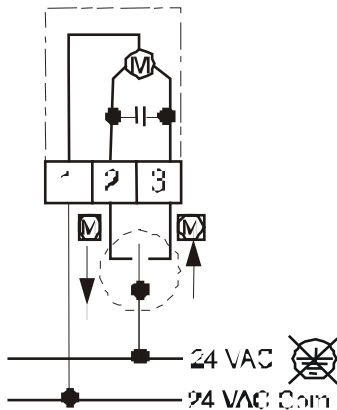

VA-7200-xx01

### Proportional model

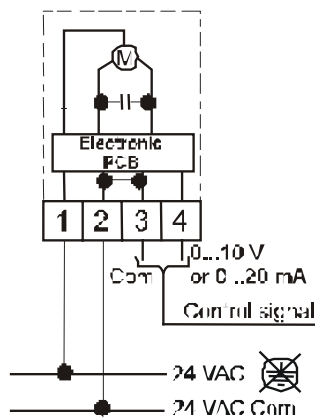

VA-7202-xx01

## Adjustments for proportional models

The adjustment procedure varies depending on whether voltage or current control is used, taking this into account, to adjust please carry out the following instructions:

1. Set the stroke jumper to match the valve stroke, this setting is approximate. Jumper location is as depicted below:

Stroke selection jumpers (J5):

- Jumper 8: 8mm
- Jumper 10: 10mm
- Jumper 13: 13mm
- Jumper 19: 19mm

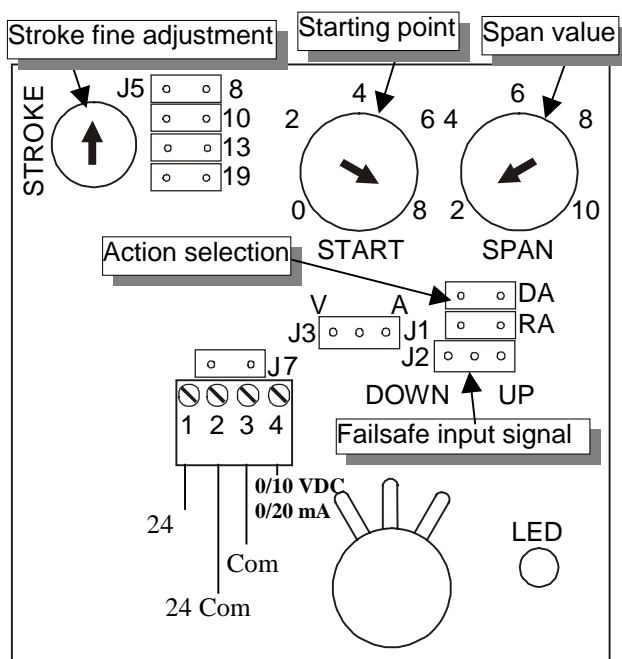

2. Set the direct / reverse action jumper (J1) so that the valve stem travels in the desired direction (as per changes in control signal)
  - DA (J1 top jumper) stem extends on signal increase.
  - RA (J1 bottom jumper) stem retracts on signal increase.
3. Select voltage (V) or current (mA) input signal to match the controller output (if the input signal selection jumper is removed the actuator defaults to voltage input).
 

Note: When mA input is selected, multiply the “start” and “span” scales by two.
4. Set the signal fail default position to “fully up”, or “fully down”, if the actuator control signal is lost i.e. an open connection, the actuator will default to this pre-designated position.
 

Note: When mA input is selected, the actuator will default to the “low” input signal position.
5. Adjust the potentiometers to the nominal values. Set the stroke fine adjustment to midpoint. Set the starting point (offset) to the “low” input signal using the scale printed on the PCB as a reference. Set the span value to the “high” input signal minus the offset; see table below. Use the scales for reference.
6. Apply the voltage specified by application (RA / DA) requirements to drive the actuator to the “fully up” position using the following table. (If mA input is selected, multiply all values by two).

### VA-72x2 PCB Components

The V / A jumper (J3) allows selection of the input signal type as follows:

- Volts
- mA

When the voltage input range (J3) is set the DOWN / UP jumper (J2) allows selection of the actuator “failsafe” stem position as follows:

- DOWN
- UP

Note: Disconnecting J7 from PCB, the power supply is interrupted. Therefore the plug must be in place for actuator operation.

### Calibration values

| Actual  |         | Reference |         |
|---------|---------|-----------|---------|
| Minimum | Maximum | Minimum   | Maximum |
| 0       | 10      | 1         | 9       |
| 0       | 5       | 1         | 4       |
| 5       | 10      | 6         | 9       |

Note: Using the calibration values ( $\pm 0.5$  V) will ensure proper close-off throughout the life of the valve (takes seat wear into account).

If the application requires values other than those given, use the **minimum actual value + 1 V** and the **maximum actual value - 1 V** to determine the reference values.

- DA: “fully up” (min. voltage)
- RA: “fully up” (max. voltage)

When the actuator is in operation the LED will illuminate.

7. Slowly turn the starting point potentiometer clockwise until the valve stem reaches stroke limit, when the valve stem is in the “fully up” position (the LED will be illuminated and there should be no gear movement).
8. Slowly turn the starting point potentiometer anti-clockwise, stop when the LED flashes or goes out.  
 Note: The actuator electronics contain a time-out feature. If calibration takes longer than 3...10 minutes, the LED will extinguish, falsely indicating a satisfactory condition. Should this occur, cycle the power to the actuator and readjust the starting point.
9. Apply the input voltage requirements specified by the application (RA / DA) to drive the valve stem to the “fully down” position as per chart in step 6.
10. To ensure that the valve stem is in the “fully down” position, slowly turn the stroke potentiometer clockwise until the valve stem reaches stroke limit (the LED will be on and there should be no gear movement).
11. Slowly turn the stroke potentiometer anti-clockwise, until the LED extinguishes.

12. If the “fully down” position cannot be achieved, return the stroke potentiometer to the nominal position and then slowly turn the span potentiometer anti-clockwise until “fully down” is achieved. Repeat step 11.
13. Adjust the voltage to drive the actuator to “fully up” position. Verify starting point adjustment.
14. Check for proper operation using the min. and max. operating voltages. Allow the actuator to complete several operating cycles.  
 Note: The LED will remain illuminated for 3...10 minutes after the actuator has completed its operation cycle.
15. Refit the cover and secure the screws.  
 The unit is now ready for operation.

**Factory Settings**

The VA-7200 is delivered with the following factory settings:

- 19 mm stroke
- 0...10 V input input signal
- Direct action
- Fail safe position “fully up”
- Starting point 1 V
- Span 8 V

**Applications**

**Actuators with built-in positioner for controllers with 0...10V output is sequential operation.**

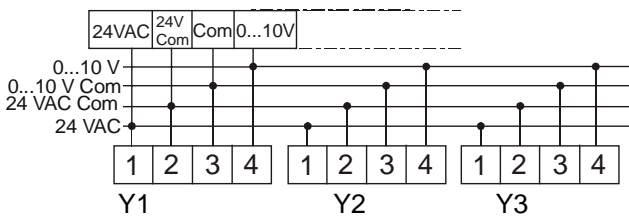

To further actuators

The controller output 0...10 V can operate several actuators with built-in electronic positioner. The electrical wiring for parallel and sequenced operation is identical.

The sequencing and action of the actuator are individually adjustable on each positioner. Each positioner has its own adjustment for starting point between 0...10 V and span between 2...10 V. Using the minimum adjustable span of 2 V therefore enables a maximum of 5 sequenced devices; further sequencing can be accomplished by using additional controller outputs. Each positioner can be switched for direct or reverse action.

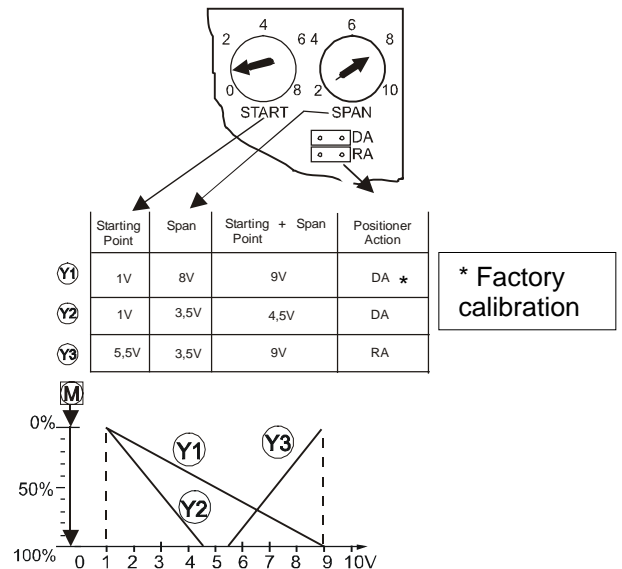

**Example of adjustments**

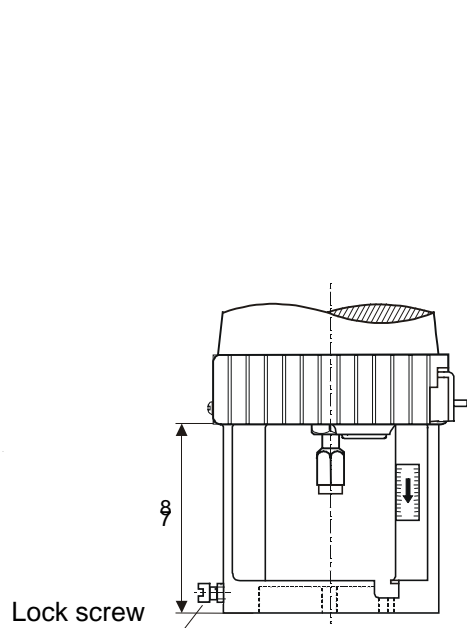
**D**imensions (in mm)

VA-7200 for VG7000 Valve Series  
(section)

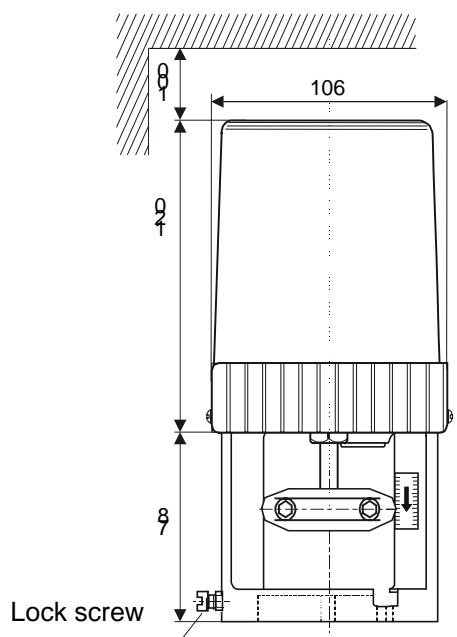

VA-7200 for VG8000, VG9000 and VGS8000  
Valve Series

## Specifications

|  |  |   |                     |
|--|--|---|---------------------|
| <b>Models:</b>   | <b>Floating</b>  | <b>Proportional<br/>0...10 VDC or 0...20 mA</b> |                     |
| <b>Type of motor:</b>  | Synchronous / reversible   |   |                     |
| <b>Supply voltage (50/60 Hz):</b>  | 24 V ± 15%<br>50...60 Hz   | 24 V ± 15%<br>50...60 Hz                        |                     |
| <b>Motor ratings:</b>  | 5 W  |   |                     |
| <b>Actual power</b>  | 5.6 VA at 50 Hz  |   |                     |
| <b>Apparent power</b>  | 6.7 VA at 60 Hz  |   |                     |
| <b>Electronic positioner ratings:</b>  | 2 VA<br>100 kΩ input impedance<br>(0...10 VDC)<br>500 Ω input impedance<br>(0...20 mA) |   |                     |
| <b>Actuator force:</b>   | 1000 N + 30% - 20%   |   |                     |
| <b>Stroke:</b>   | 20 mm maximum; 8, 10, 13, 19 mm selectable   |   |                     |
| <b>Nominal speed at 50 Hz (60 Hz):</b>   | 4 (3.2) s / mm   |   |                     |
| <b>Enclosure protection:</b>   | IP 42 (EN 60529)   |   |                     |
| <b>Materials:</b>  |  |   |                     |
| <b>Enclosure:</b>  | Self extinguishing VO-UL 94 ABS + PC   |   |                     |
| <b>Hand wheel:</b>   | Self extinguishing nylon PA  |   |                     |
| <b>Yoke:</b>   | Die cast aluminium   |   |                     |
| <b>Ambient Operating condition:</b>  | -5 to +55, °C, non condensing  |   |                     |
| <b>Ambient Storage condition:</b>  | -20 to +65 °C, non condensing  |   |                     |
| <b>Electrical connections:</b>   | 2.5 mm <sup>2</sup>  | 2.5 mm <sup>2</sup>                             | 1.5 mm <sup>2</sup> |
| <b>Net weight:</b>   | 1.0 kg   |   |                     |
|  <b>Compliance:</b> | EMC directive 89/336 EEC: EN 61000-6-2, EN 61000-6-3                                   |   |                     |

The performance specifications are nominal and conform to acceptable industrial standards. For application at conditions beyond these specifications, consult the local Johnson Controls office.  
Johnson Controls, Inc. shall not be liable for damages resulting from misapplication or misuse of its products.

**JOHNSON  
CONTROLS**

**Johnson Controls International, Inc.**

Headquarters:  
European Customer Service Center:  
European Factories:  
Branch Offices

Milwaukee, Wisconsin, USA  
Westendhof 3, D-45143 Essen, Germany  
Essen (Germany), Leeuwarden (The Netherlands) and Lomagna (Italy)  
Principal European Cities.